

3º ETAPA

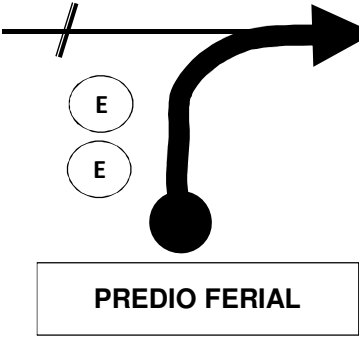

RESUMEN 3° ETAPA

SECTOR	NEUTRALIZA	LUGAR	PC N°	CONTROL DE SELLO	KM TOTAL	KM PARCIAL
1	LARGADA	CATAMARCA			0.000	0.000
1		PATA DE BUEY	30			20.xxx
1		EL RODEO	31			12.xxx
1		LA PUERTA	32			14.xxx
1		LAS TALAS	33			12.xxx
1		SINGUIL	34			18.xxx
1		BALCOZNA	35			20.xxx
1		CUESTA TOTORAL 1	36			17.xxx
1	NEUTRALIZA	LOS ALTOS		LOS ALTOS	190.470	190.470
1	NEUTRALIZA	ALIJILAN		ALIJILAN	202.270	11.800
1	NEUTRALIZA	LOS ALTOS			214.000	11.730
2		CUESTA TOTORAL 2	37			17.xxx
2		LA MERDED	38			29.xxx
2	LLEGADA	CATAMARCA		CATAMARCA	303.620	89.620

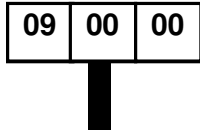

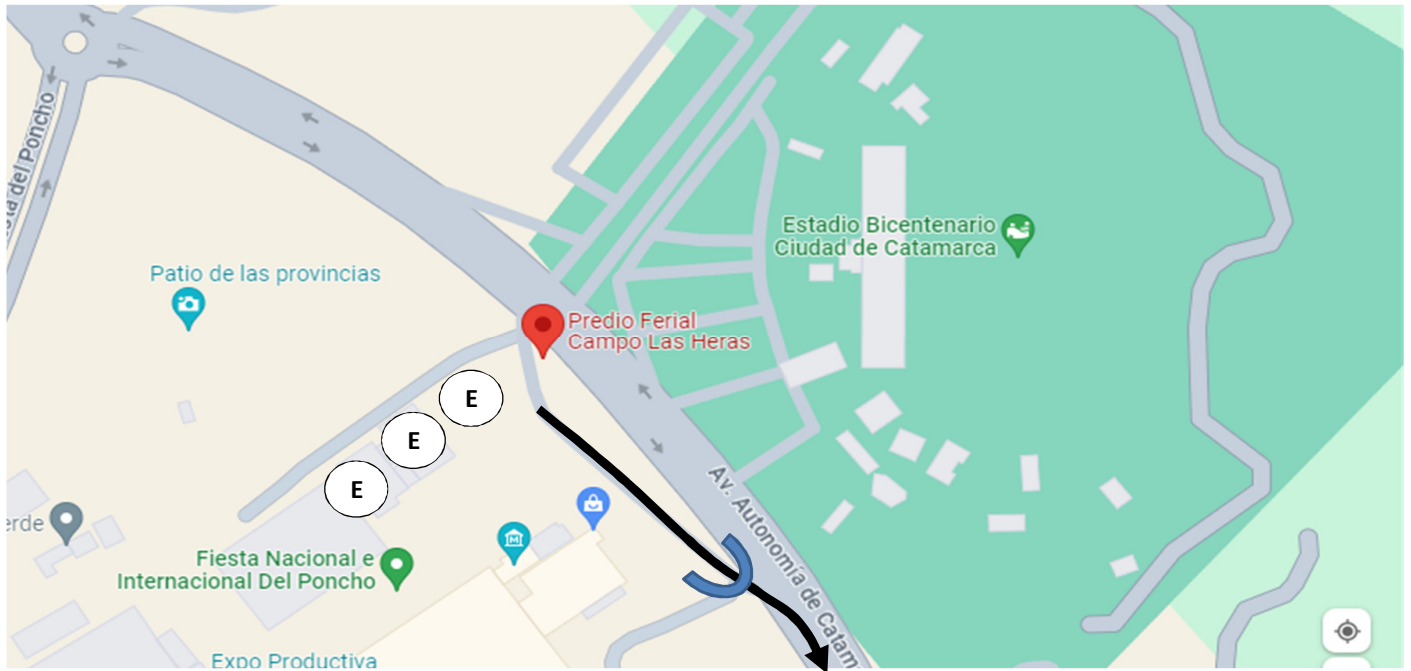
XX° GRAN PREMIO ARGENTINO HISTORICO

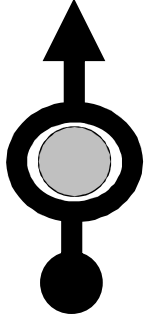
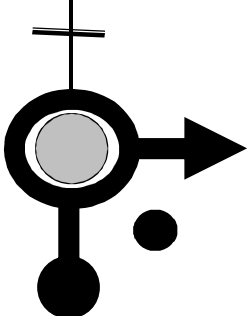
Sector Clasificadorio Nro: 1			CATAMARCA	ETAPA N°	
Km Totales del Sector : 202.270			HOSTERIA ALIJILAN	3	
Vel.	Dist. Total	Dist. Parcial	Direccion y Ubicacion de la Referencia	Referencia / Informacion	Hora de Carrera HH:MM:SS.CC
40	0.000	0.000		 LARGADA EN PREDIO FERIAL SOBRE CALLE COLECTORA	00:00:00.00



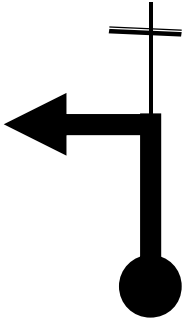
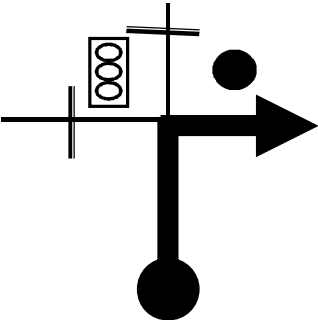
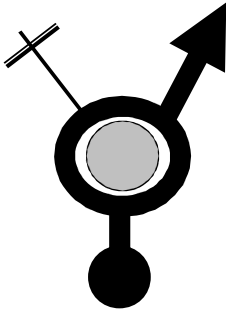
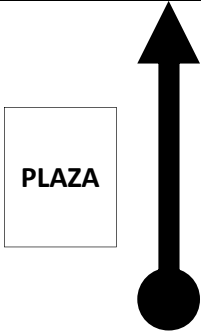
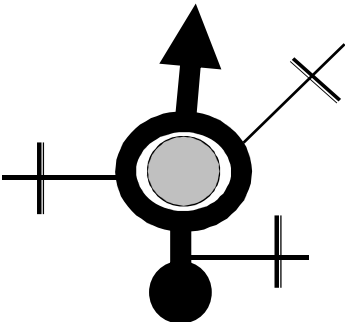

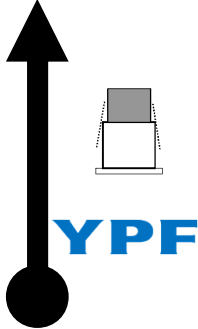
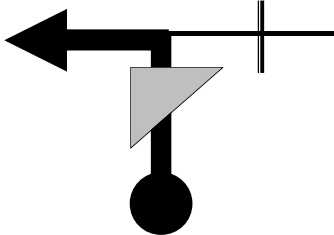
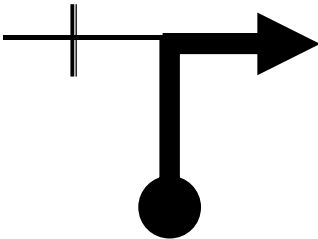
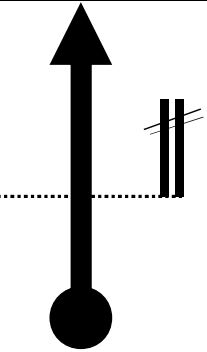
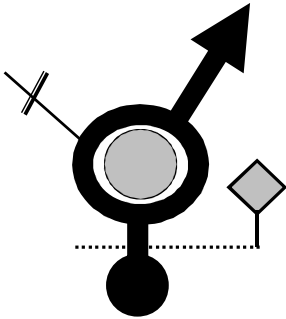



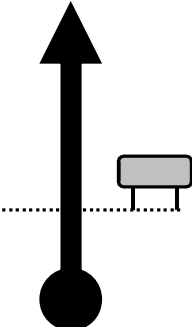
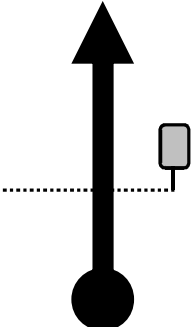
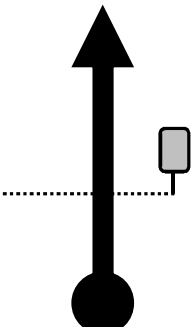
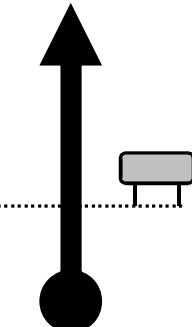
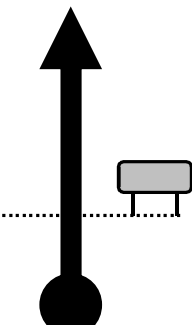

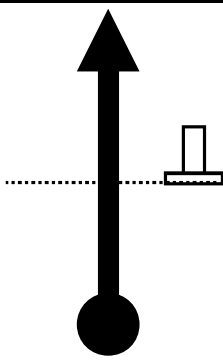
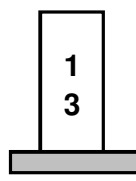
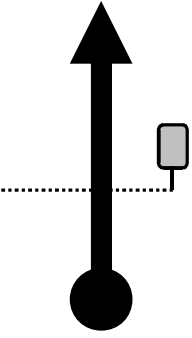
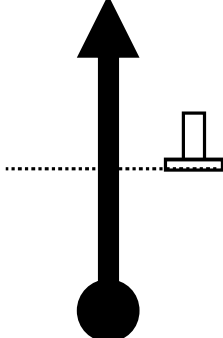
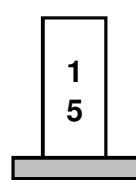
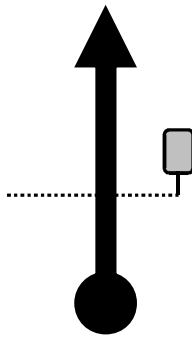

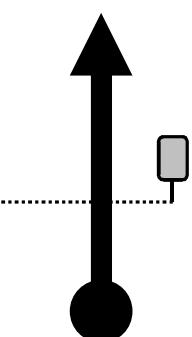

40	0.200	0.200			00:00:xx.xx
40	0.480	0.280		 CARTEL PROXIMAMENTE HOTEL HOWARD JHONSON TOMAR A LA DERECHA	 00:00:xx.xx
40	velocidad proxima referencia	XX° GRAN PREMIO ARGENTINO HISTORICO 2023			PAG. N° 1

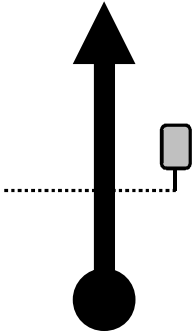
Sector Clasificadorio Nro: 1			CATAMARCA	ETAPA N°	
Km Totales del Sector : 202.270			HOSTERIA ALIJILAN	3	
Vel.	Dist. Total	Dist. Parcial	Direccion y Ubicacion de la Referencia	Referencia / Informacion	Hora de Carrera HH:MM:SS.CC
40	0.710	0.230		TOMAR A LA IZQUIERDA POR BVAR. SAN MARTIN	00:01:xx.xx
40	1.720	1.010		● PILETAS TOMAR A LA DERECHA POR AV. PTE. CASTILLO	00:02:xx.xx
40	2.250	0.530		CONTINUAR POR AV. BELGRANO	00:03:xx.xx
30	4.350	2.100		PLAZA VIRGEN DEL VALLE	00:07:xx.xx
30	4.750	0.400		SEGUIR POR AV. ILLIA	00:08:xx.xx
40	velocidad proxima referencia	XX° GRAN PREMIO ARGENTINO HISTORICO 2023			PAG. N° 2

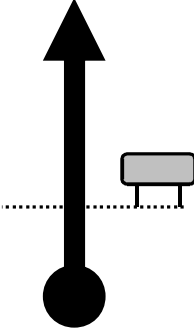

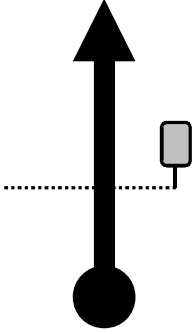

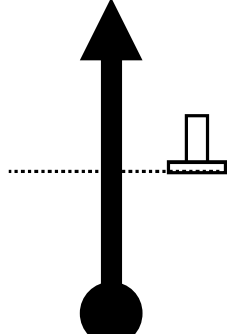
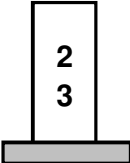
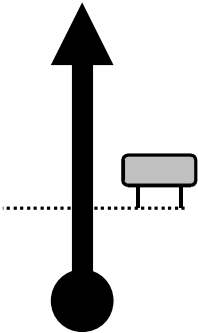
Sector Clasificadorio Nro: 1			CATAMARCA	ETAPA N°	
Km Totales del Sector : 202.270			HOSTERIA ALIJILAN	3	
Vel.	Dist. Total	Dist. Parcial	Direccion y Ubicacion de la Referencia	Referencia / Informacion	Hora de Carrera HH:MM:SS.CC
40	6.070	1.320		ZONA DE LOMADAS	00:10:xx.xx
40	7.030	0.960		TOMAR POR AV. J.P. SEGUNDO	00:11:xx.xx
40	8.800	1.770		TOMAR A LA DERECHA POR RUTA 4 A EL RODEO CONTROL POLICIAL	00:14:xx.xx
40	9.900 0.000	1.100 0.000		COLUMNA DE CEMENTO MARCA "CO3" COMIENZA ZONA CONTROL ODOMETRO	00:21:00.00
45	<u>0.745</u>	<u>0.745</u>			00:21:59.62
45	velocidad proxima referencia	XX° GRAN PREMIO ARGENTINO HISTORICO 2023			PAG. N° 3

Sector Clasificadorio Nro: 1			CATAMARCA	ETAPA N°	
Km Totales del Sector : 202.270			HOSTERIA ALIJILAN	3	
Vel.	Dist. Total	Dist. Parcial	Direccion y Ubicacion de la Referencia	Referencia / Informacion	Hora de Carrera HH:MM:SS.CC
45	<u>2.705</u>	<u>1.960</u>		LA BREA	00:24:36.42
65	<u>3.650</u>	<u>0.945</u>		PROHIBIDO ARROJAR BASURA	00:25:28.75
65	<u>4.887</u>	<u>1.237</u>		RIESGO HIDRICO ZONA INUNDABLE	00:26:37.25
65	<u>6.190</u>	<u>1.303</u>		← GRANIZO CARTEL DE MADERA	00:27:49.42
65	<u>7.411</u>	<u>1.221</u>		RECUPERACION SITIO ARQUEOLOGICO PATA DE BUEY	00:28:57.05
65	velocidad proxima referencia	XX° GRAN PREMIO ARGENTINO HISTORICO 2023			PAG. N° 4



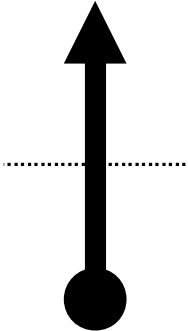
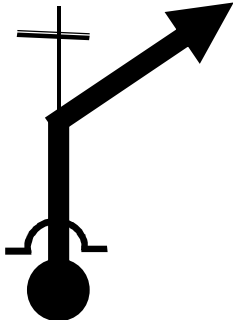

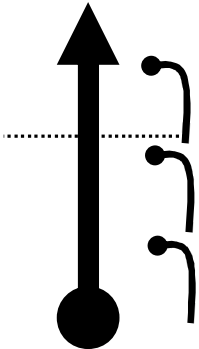
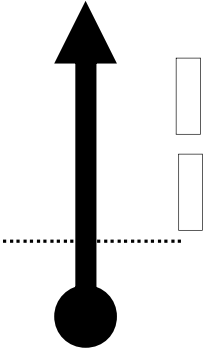
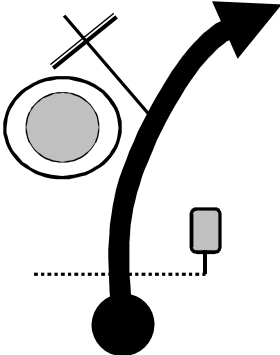

Sector Clasificadorio Nro: 1			CATAMARCA	ETAPA N°	
Km Totales del Sector : 202.270			HOSTERIA ALIJILAN	3	
Vel.	Dist. Total	Dist. Parcial	Direccion y Ubicacion de la Referencia	Referencia / Informacion	Hora de Carrera HH:MM:SS.CC
65	<u>8.380</u>	<u>0.969</u>		 FIN ZONA CONTROL ODOMETROS	00:29:50.69
65	8.860 0.000	0.480 0.000		PANCARTA ROJA FRENTE A 1° COL DE CEMENTO CON MARCA "L" COMIENZA P.C. N° 30	00:35:00.00
63	1.480	1.480			00:36:24.58
63	2.507	1.026			00:37:23.23
63	3.504	0.997			00:38:20.21
63	velocidad proxima referencia	XX° GRAN PREMIO ARGENTINO HISTORICO 2023			PAG. N° 5

Sector Clasificadorio Nro: 1			CATAMARCA	ETAPA N°	
Km Totales del Sector : 202.270			HOSTERIA ALIJILAN	3	
Vel.	Dist. Total	Dist. Parcial	Direccion y Ubicacion de la Referencia	Referencia / Informacion	Hora de Carrera HH:MM:SS.CC
63	4.990	1.486			00:39:45.14
63	5.877	0.887			00:40:35.84
63	7.892	2.015		 COMIENZO ZONA DE CONTROL	00:42:30.98
63	9.5xx	1.6xx			00:44:xx.xx
45	12.6xx	3.0xx		 	00:48:__. __
45	velocidad proxima referencia	XX° GRAN PREMIO ARGENTINO HISTORICO 2023			PAG. N° 6

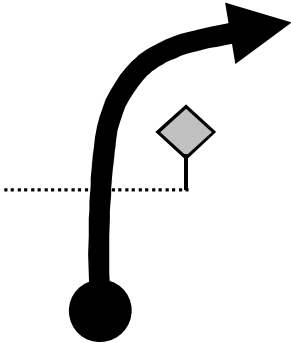
Sector Clasificadorio Nro: 1			CATAMARCA	ETAPA N°	
Km Totales del Sector : 202.270			HOSTERIA ALIJILAN	3	
Vel.	Dist. Total	Dist. Parcial	Direccion y Ubicacion de la Referencia	Referencia / Informacion	Hora de Carrera HH:MM:SS.CC
45	A PARTIR DE LAS 00:49:00.00 Y ANTES DE LAS 00:51:00.00 ATRASE 8 SEGUNDOS				
45	15.8xx	3.1xx	CAMBIE LA VELOCIDAD A 63 KM/H. CUANDO SU RELOJ INDIQUE →		00:52:33.00
63				AS PANCARTA BLANCA CON LEYENDA "A S" AUTOCONTROL SECRETO: 089	
63	19.0xx	3.2xx			00:55:xx.xx
65	20.3xx	1.3xx		ZONA URBANA AUTOCONTROL: 090 FIN ZONA DE CONTROL	00:56:__.__
40	velocidad proxima referencia	XX° GRAN PREMIO ARGENTINO HISTORICO 2023			PAG. N° 7

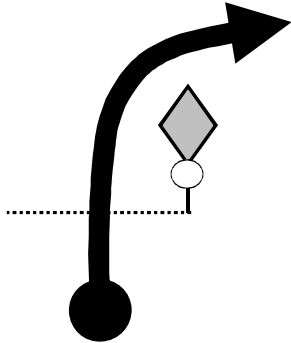
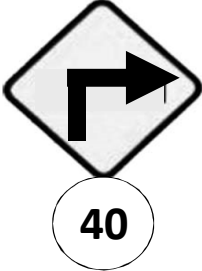
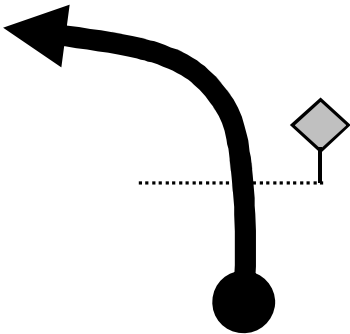
Sector Clasificadorio Nro: 1			CATAMARCA	ETAPA N°	
Km Totales del Sector : 202.270			HOSTERIA ALIJILAN	3	
Vel.	Dist. Total	Dist. Parcial	Direccion y Ubicacion de la Referencia	Referencia / Informacion	Hora de Carrera HH:MM:SS.CC
40	21.450	1.1xx		CONTROL POLICIAL	00:58:xx.xx
40	22.500	1.050		 LOMADAS TOMAR A LA DERECHA A CANCHAS DE CESPED SINTETICO	01:00:xx.xx
40	23.120 0.000	0.620 0.000		ULTIMA COLUMNA DE LUZ AMARILLA COMIENZA P.C. N° 31	01:05:00.00
50	0.996	0.996		PRINCIPIO DE 1° ALCANTARILLA DE PIEDRA	01:06:11.69
50	2.139	1.144		 LA CONSTANCIA	01:07:34.03
50	velocidad proxima referencia	XX° GRAN PREMIO ARGENTINO HISTORICO 2023			PAG. N° 8

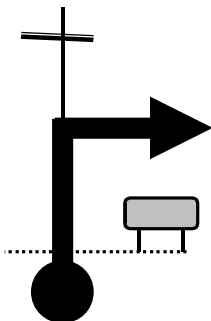



Sector Clasificatorio Nro: 1			CATAMARCA	ETAPA N°	
Km Totales del Sector : 202.270			HOSTERIA ALIJILAN	3	
Vel.	Dist. Total	Dist. Parcial	Direccion y Ubicacion de la Referencia	Referencia / Informacion	Hora de Carrera HH:MM:SS.CC
50	3.359	1.220			01:09:01.87
50	5.056	1.697			01:11:04.04
50	7.363	2.307		 COMIENZO ZONA DE CONTROL	01:13:50.14
50	9.0xx	1.6xx		 AUTOCONTROL: 091	01:15:__.__
50				AS PANCARTA BLANCA CON LEYENDA "A S" AUTOCONTROL SECRETO: 092	
50	velocidad proxima referencia	XX° GRAN PREMIO ARGENTINO HISTORICO 2023			PAG. N° 9

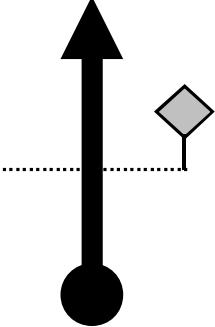
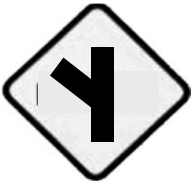
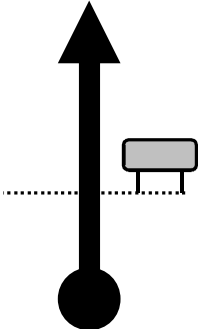
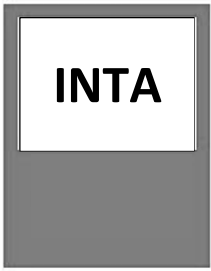
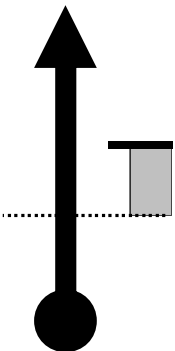
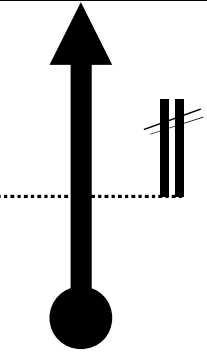
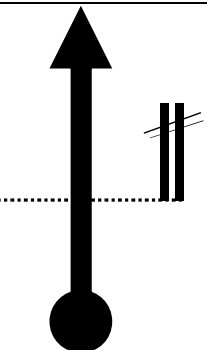



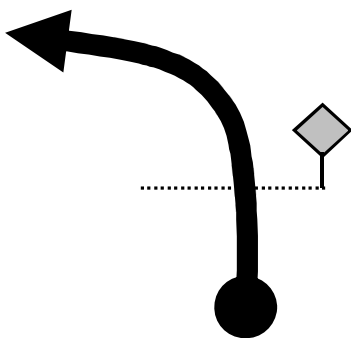

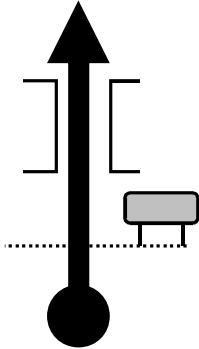
Sector Clasificadorio Nro: 1			CATAMARCA	ETAPA N°	
Km Totales del Sector : 202.270			HOSTERIA ALIJILAN	3	
Vel.	Dist. Total	Dist. Parcial	Direccion y Ubicacion de la Referencia	Referencia / Informacion	Hora de Carrera HH:MM:SS.CC
50	11.2xx	2.2xx			01:18:xx.xx
45	12.4xx	1.1xx		 PRECUACION!!!!!!	01:20:xx.xx
45	ATENCION CURVA CERRADA				
45	12.8xx	0.4xx		 AUTOCONTROL: 093 FIN ZONA DE CONTROL	01:20:__.__
40	13.650	0.8xx		 ZONA URBANA LOMADAS	01:21:xx.xx
40	velocidad proxima referencia	XX° GRAN PREMIO ARGENTINO HISTORICO 2023			PAG. N° 10

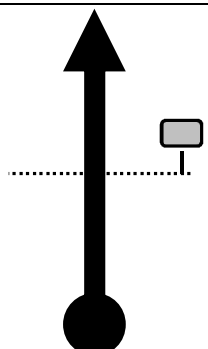
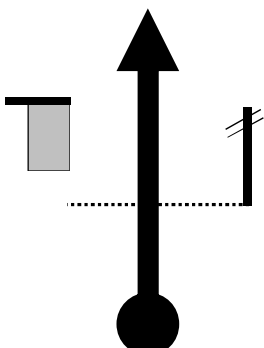

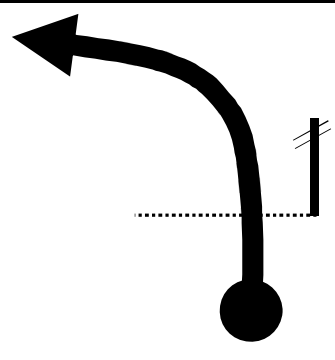
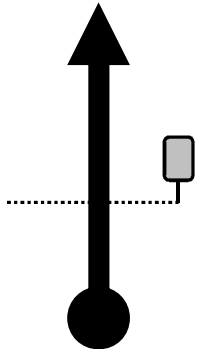
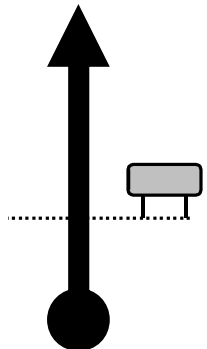

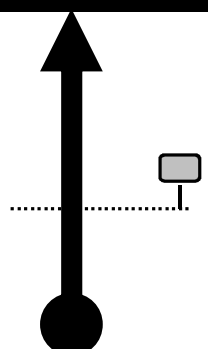

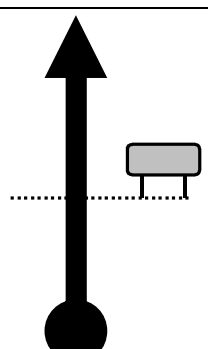
Sector Clasificadorio Nro: 1			CATAMARCA	ETAPA N°	
Km Totales del Sector : 202.270			HOSTERIA ALIJILAN	3	
Vel.	Dist. Total	Dist. Parcial	Direccion y Ubicacion de la Referencia	Referencia / Informacion	Hora de Carrera HH:MM:SS.CC
40	14.100	0.450		 SEGUIR POR ASFALTO	01:22:xx.xx
40	14.300	0.200		 SEGUIR POR ASFALTO	01:22:xx.xx
40	15.800	1.500		CRUZAR RIO DEL VALLE	01:25:xx.xx
40	16.050	0.250		TOMAR RUTA 1 A LA PUERTA	01:25:xx.xx
40	16.870 0.000	0.820 0.000		PRINCIPIO GUARDARRAILL CORTO PINTADO DE AMARILO COMIENZA P.C. N° 32	01:30:00.00
70	velocidad proxima referencia	XX° GRAN PREMIO ARGENTINO HISTORICO 2023			PAG. N° 11

Sector Clasificadorio Nro: 1			CATAMARCA	ETAPA N°	
Km Totales del Sector : 202.270			HOSTERIA ALIJILAN	3	
Vel.	Dist. Total	Dist. Parcial	Direccion y Ubicacion de la Referencia	Referencia / Informacion	Hora de Carrera HH:MM:SS.CC
70	1.081	1.081			01:30:55.59
70	2.624	1.543			01:32:14.93
70	4.188	1.564		PRINCIPIO DE REFUGIO	01:33:35.37
70	5.449	1.261		COLUMNA DE CEMENTO DOBLE CON CINTA ROJA	01:34:40.21
70	7.525	2.077		COLUMNA DE CEMENTO DOBLE CON CINTA ROJA COMIENZO ZONA DE CONTROL	01:36:27.01
70	velocidad proxima referencia	XX° GRAN PREMIO ARGENTINO HISTORICO 2023			PAG. N° 12

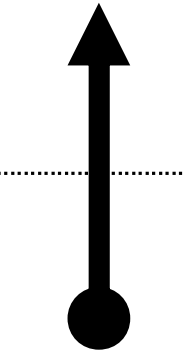
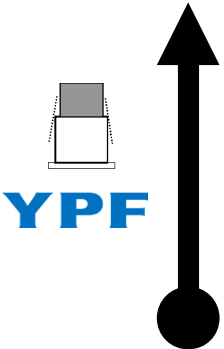
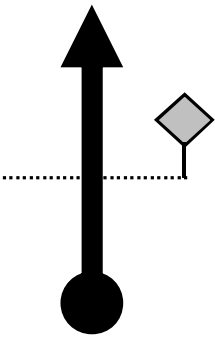
Sector Clasificadorio Nro: 1			CATAMARCA	ETAPA N°	
Km Totales del Sector : 202.270			HOSTERIA ALIJILAN	3	
Vel.	Dist. Total	Dist. Parcial	Direccion y Ubicacion de la Referencia	Referencia / Informacion	Hora de Carrera HH:MM:SS.CC
70				<div style="border: 1px solid black; padding: 5px; display: inline-block; margin-bottom: 10px;">A S</div> <p>PANCARTA BLANCA CON LEYENDA "A S"</p> <div style="border: 1px solid gray; padding: 5px; background-color: #f0f0f0; margin-top: 10px;"> <p>AUTOCONTROL SECRETO: 094</p> </div>	
70	10.4xx	2.9xx		<div style="border: 1px solid black; padding: 5px; background-color: black; color: white; display: inline-block; margin-bottom: 10px;">COLPES</div> <div style="border: 1px solid gray; padding: 5px; background-color: #f0f0f0; margin-top: 10px;"> <p>AUTOCONTROL: 095</p> </div>	<p>01:xx:__.__</p> <p>ENTRE 38:55 y 39:05</p>
70	14.4xx	4.0xx		<div style="border: 1px solid black; padding: 5px; display: inline-block; margin-bottom: 10px;"> </div> <div style="border: 1px solid gray; padding: 5px; background-color: #f0f0f0; margin-top: 10px;"> <p>AUTOCONTROL: 096</p> </div> <p>FIN ZONA DE CONTROL</p>	01:42:__.__
70	14.980 0.000	0.4xx 0.000		<p>COLUMNA DE CEMENTO DOBLE CON MARCA "L"</p> <p>COMIENZA P.C. N° 33</p>	01:46:00.00
78	1.000	1.000		<p>COLUMNA DE CEMENTO DETRÁS DE GUARDARRAILL CORTO</p>	01:46:46.18
78	velocidad proxima referencia	XX° GRAN PREMIO ARGENTINO HISTORICO 2023			PAG. N° 13

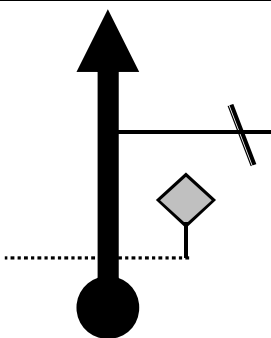

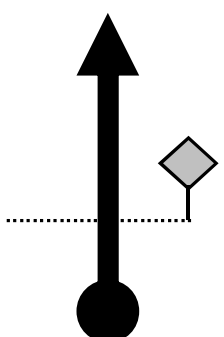

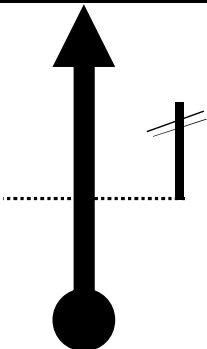
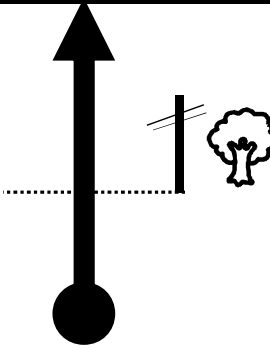
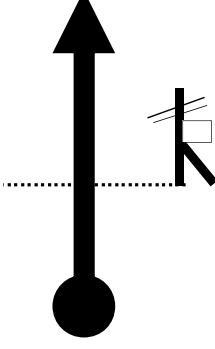
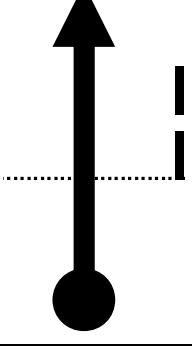
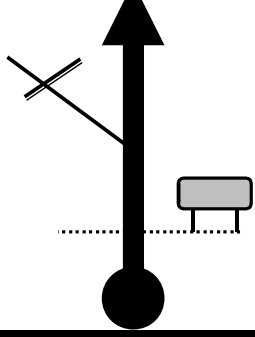
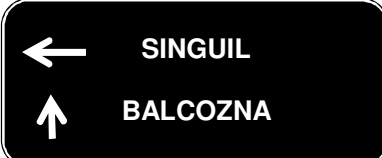

Sector Clasificadorio Nro: 1			CATAMARCA	ETAPA N°	
Km Totales del Sector : 202.270			HOSTERIA ALIJILAN	3	
Vel.	Dist. Total	Dist. Parcial	Direccion y Ubicacion de la Referencia	Referencia / Informacion	Hora de Carrera HH:MM:SS.CC
78	2.491	1.490			01:47:54.96
78	3.153	0.662		RIO LOS PUESTOS ATENCION BADEN	01:48:25.51
78	ATENCION EN LA REFERENCIA ANTERIOR BAJE A 40 KM/H. Y LUEGO RECUPERE PARA PASAR EL BADEN				
78	4.583	1.430		CABAÑAS 12Km CARTEL CHICO	01:49:31.51
78	6.104	1.522		PALO DE LUZ CON CABLES QUE CRUZAN LA RUTA FRENTE A REFUGIO	01:50:41.74
78	velocidad proxima referencia	XX° GRAN PREMIO ARGENTINO HISTORICO 2023			PAG. N° 14

Sector Clasificadorio Nro: 1			CATAMARCA	ETAPA N°	
Km Totales del Sector : 202.270			HOSTERIA ALJILAN	3	
Vel.	Dist. Total	Dist. Parcial	Direccion y Ubicacion de la Referencia	Referencia / Informacion	Hora de Carrera HH:MM:SS.CC
78	7.533	1.429		ULTIMA COLUMNA DE CEMENTO ANTES DE CURVA IZQUIERDA COMIENZO ZONA DE CONTROL	01:51:47.68
78				A S PANCARTA BLANCA CON LEYENDA "A S" AUTOCONTROL SECRETO: 097	
78	9.5xx	2.0xx			01:53:xx.xx
70	11.7xx	2.1xx		 CARTEL CHICO AUTOCONTROL: 098	01:55:__. __
70	12.8xx	1.1xx		 AUTOCONTROL: 099 FIN ZONA DE CONTROL	01:56:__. __
60	velocidad proxima referencia	XX° GRAN PREMIO ARGENTINO HISTORICO 2023			PAG. N° 15

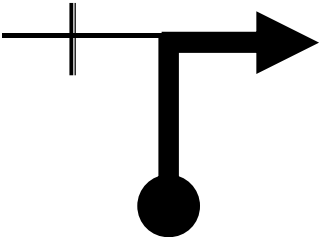

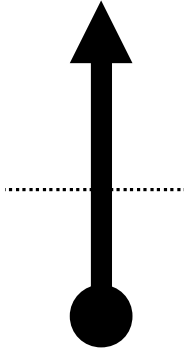

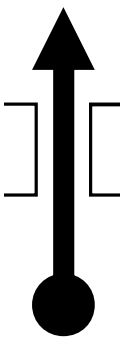

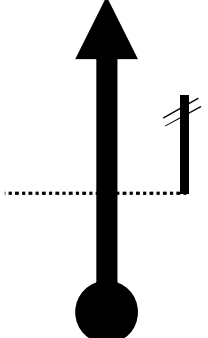
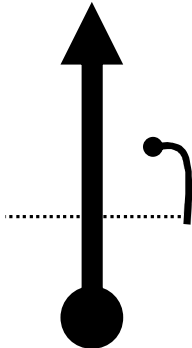
Sector Clasificadorio Nro: 1			CATAMARCA	ETAPA N°	
Km Totales del Sector : 202.270			HOSTERIA ALIJILAN	3	
Vel.	Dist. Total	Dist. Parcial	Direccion y Ubicacion de la Referencia	Referencia / Informacion	Hora de Carrera HH:MM:SS.CC
60	13.500	0.6xx		ZONA URBANA EL TALA	01:56:xx.xx
60	14.650	1.150		SURTIDORES ECOLOGICOS (CONTAINERS)	01:57:xx.xx
60	16.930	2.280		 PLAZA DE LOS VARELA ZONA URBANA	02:05:xx.xx
40	18.020	1.090		 SEGUIR AL FRENTE POR RUTA 1	02:06:xx.xx
40	21.500	3.480		 BADEN	02:12:xx.xx
40	velocidad proxima referencia	XX° GRAN PREMIO ARGENTINO HISTORICO 2023			PAG. N° 16

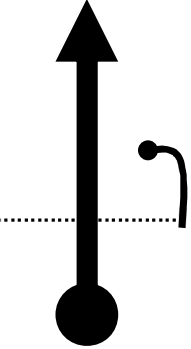
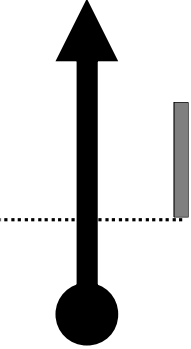
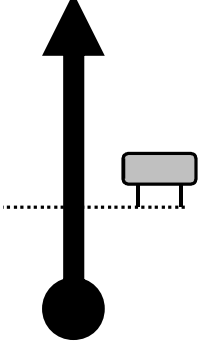
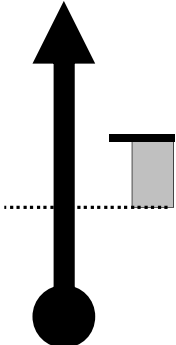
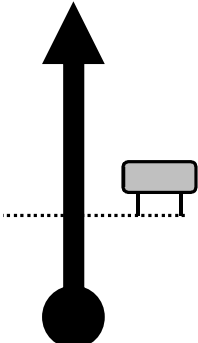

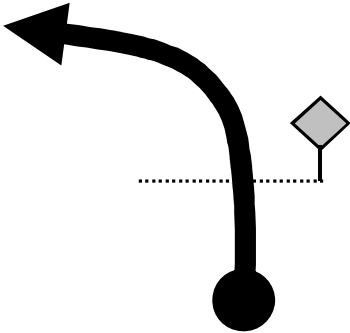

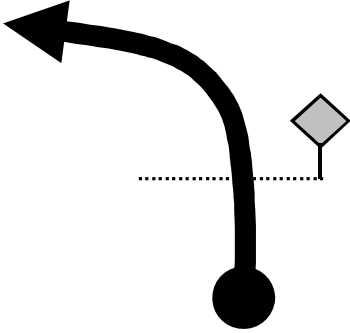

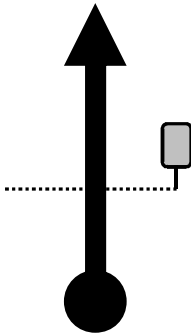
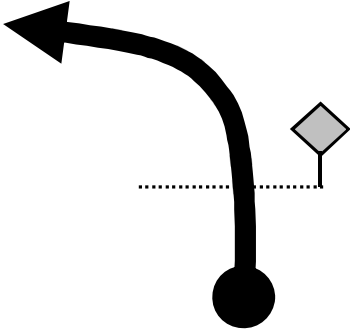
Sector Clasificadorio Nro: 1			CATAMARCA	ETAPA N°	
Km Totales del Sector : 202.270			HOSTERIA ALIJILAN	3	
Vel.	Dist. Total	Dist. Parcial	Direccion y Ubicacion de la Referencia	Referencia / Informacion	Hora de Carrera HH:MM:SS.CC
40	23.500	2.000		<p>4° POSTE DE LUZ PINTADO DE AMARILLO MARCA "L" EN RUTA</p> <p>COMIENZA P.C. N° 34</p>	02:19:00.00
	0.000	0.000			
55	1.204	1.204		<p>PALO DE LUZ JUNTO A ARBOL</p>	02:20:18.82
55	2.293	1.089		<p>PALO DE LUZ DOBLE CON TRANSFORMADOR</p>	02:21:30.11
55	3.742	1.449		<p>1° PILOTE DE CEMENTO BLANCO</p>	02:23:04.94
55	5.415	1.673			02:24:54.42
45	velocidad proxima referencia	XX° GRAN PREMIO ARGENTINO HISTORICO 2023			PAG. N° 17

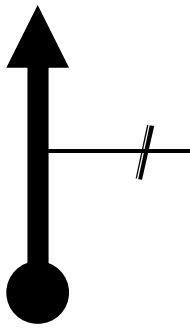

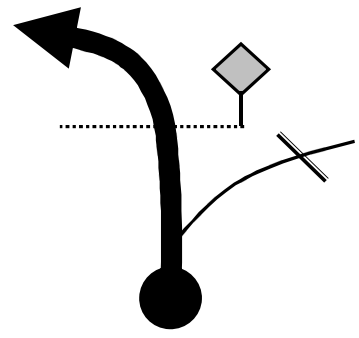

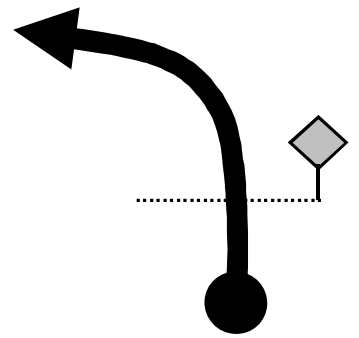

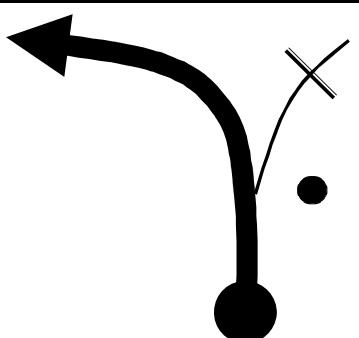
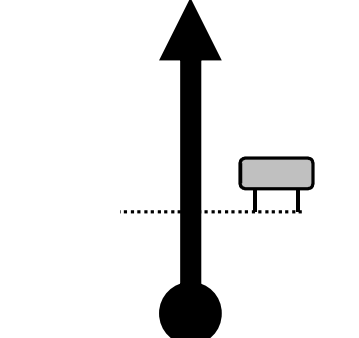
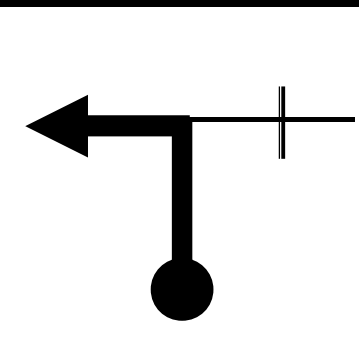
Sector Clasificadorio Nro: 1			CATAMARCA	ETAPA N°	
Km Totales del Sector : 202.270			HOSTERIA ALIJILAN	3	
Vel.	Dist. Total	Dist. Parcial	Direccion y Ubicacion de la Referencia	Referencia / Informacion	Hora de Carrera HH:MM:SS.CC
45	6.613	1.199		1° PILOTE DE CEMENTO PINTADO DE AMARILLO	02:26:30.32
45	7.623	1.010		1° PILOTE DE CEMENTO PINTADO DE AMARILLO COMIENZO ZONA DE CONTROL	02:27:51.09
45	11.1xx	3.5xx		1° PILOTE DE CEMENTO PINTADO DE AMARILLO AUTOCONTROL: 100	02:32:__.__
45				A S PANCARTA BLANCA CON LEYENDA "A S" AUTOCONTROL SECRETO: 101	
45	18.6xx	7.4xx		PILOTE DE CEMENTO MARCA "F" AUTOCONTROL: 102 FIN ZONA DE CONTROL	02:42:__.__
40	velocidad proxima referencia	XX° GRAN PREMIO ARGENTINO HISTORICO 2023			PAG. N° 18



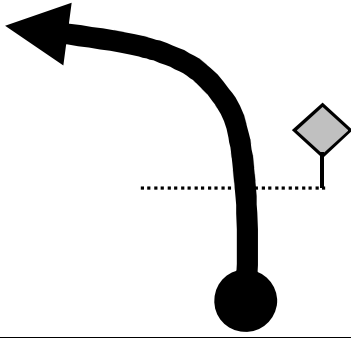

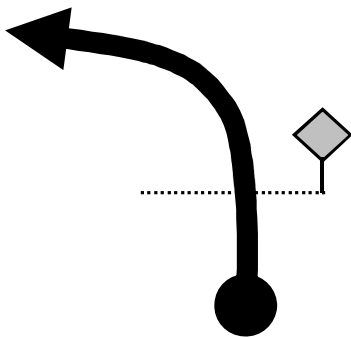

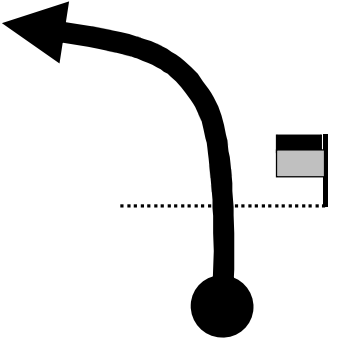
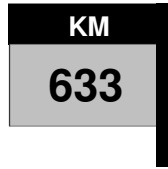
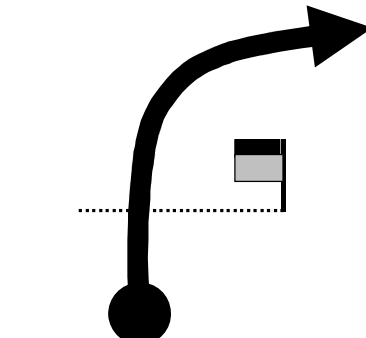
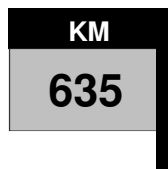
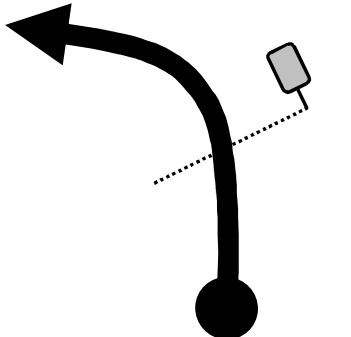
Sector Clasificadorio Nro: 1			CATAMARCA	ETAPA N°	
Km Totales del Sector : 202.270			HOSTERIA ALIJILAN	3	
Vel.	Dist. Total	Dist. Parcial	Direccion y Ubicacion de la Referencia	Referencia / Informacion	Hora de Carrera HH:MM:SS.CC
40	18.800	0.1xx		 CONTROL POLICIAL TOMAR A LA DERECHA POR RUTA 9 A BALCOZNA	02:42:xx.xx
40	19.000	0.200		 ZONA DE OBRAS VIALES ASFALTO Y RIPIO POR 4 Km	02:43:xx.xx
40	22.190	3.190		 BADEN PROFUNDO	02:47:xx.xx
40	25.460 0.000	3.270 0.000		PALO DE LUZ 020 024 DESPUES DE ULTIMA COLUMNA DE LUZ AMARILLA DE LA IZQUIERDA COMIENZA P.C. N° 35	02:56:00.00
68	0.982	0.982		<u>ULTIMA</u> COLUMNA DE LUZ AMARILLA	02:56:51.98
68	velocidad proxima referencia	XX° GRAN PREMIO ARGENTINO HISTORICO 2023			PAG. N° 19

Sector Clasificadorio Nro: 1			CATAMARCA	ETAPA N°	
Km Totales del Sector : 202.270			HOSTERIA ALIJILAN	3	
Vel.	Dist. Total	Dist. Parcial	Direccion y Ubicacion de la Referencia	Referencia / Informacion	Hora de Carrera HH:MM:SS.CC
68	2.576	1.594		PRIMER COLUMNA DE LUZ AMARILLA	02:58:16.39
68	3.704	1.128		COLUMNA DE CEMENTO SOLA	02:59:16.12
68	4.591	0.886		TIERRA VERDE	03:00:03.03
68	8.845	4.255		PRINCIPIO DE REFUGIO COMIENZO ZONA DE CONTROL	03:03:48.27
68	11.0xx	2.2xx		EL ROSARIO AUTOCONTROL: 103	03:05:__.__
68	velocidad proxima referencia	XX° GRAN PREMIO ARGENTINO HISTORICO 2023			PAG. N° 20

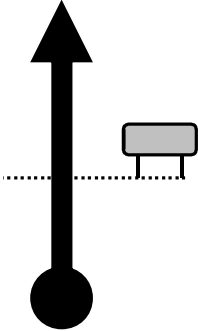

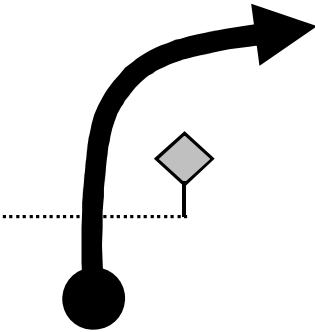

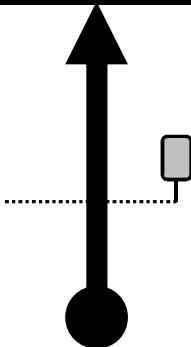

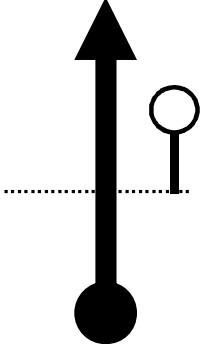
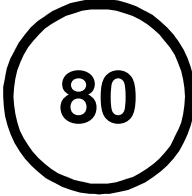

Sector Clasificadorio Nro: 1			CATAMARCA	ETAPA N°	
Km Totales del Sector : 202.270			HOSTERIA ALIJILAN	3	
Vel.	Dist. Total	Dist. Parcial	Direccion y Ubicacion de la Referencia	Referencia / Informacion	Hora de Carrera HH:MM:SS.CC
68	13.2xx	2.1xx			03:07:xx.xx
65	16.1xx	2.8xx			03:10:xx.xx
70				<div style="border: 1px solid black; padding: 5px; text-align: center; font-weight: bold; font-size: 2em;">A S</div> <p>PANCARTA BLANCA CON LEYENDA "A S"</p> <div style="border: 1px solid gray; padding: 5px; text-align: center; font-weight: bold;">AUTOCONTROL SECRETO: 104</div>	
70	18.1xx	2.0xx			03:12:xx.xx
68	19.6xx	1.4xx		SEGUIR AL FRENTE POR RUTA 9	03:13:xx.xx
68	velocidad proxima referencia	XX° GRAN PREMIO ARGENTINO HISTORICO 2023			PAG. N° 21

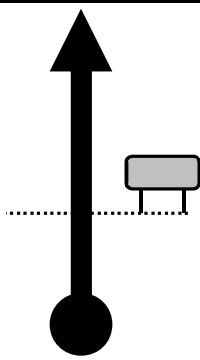
Sector Clasificadorio Nro: 1			CATAMARCA	ETAPA N°	
Km Totales del Sector : 202.270			HOSTERIA ALJILAN	3	
Vel.	Dist. Total	Dist. Parcial	Direccion y Ubicacion de la Referencia	Referencia / Informacion	Hora de Carrera HH:MM:SS.CC
68	19.8xx	0.2xx		 AUTOCONTROL: 105	03:13:__.__
68	22.4xx	2.6xx		 FIN ZONA DE CONTROL	03:15:xx.xx
80	32.690	10.2xx		● LA MERCED	03:23:xx.xx
80	33.650	0.960		ZONA URBANA	03:24:xx.xx
40	34.640	0.990		 TOMAR A LA IZQUIERDA POR RUTA 38 A TUCUMAN	03:25:xx.xx
40	velocidad proxima referencia	XX° GRAN PREMIO ARGENTINO HISTORICO 2023			PAG. N° 22

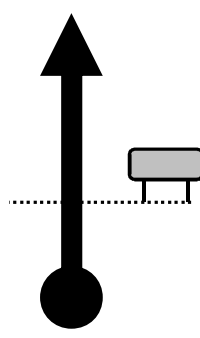
Sector Clasificadorio Nro: 1			CATAMARCA	ETAPA N°	
Km Totales del Sector : 202.270			HOSTERIA ALJILAN	3	
Vel.	Dist. Total	Dist. Parcial	Direccion y Ubicacion de la Referencia	Referencia / Informacion	Hora de Carrera HH:MM:SS.CC
40	35.580 0.000	0.940 0.000		 COMIENZA P.C. N° 36	03:31:00.00
60	1.215	1.215			03:32:12.92
60	2.177	0.962			03:33:10.61
60	4.204	2.028			03:35:12.26
60	6.900	2.696		 1° CARTEL DE TRES	03:37:54.02
60	velocidad proxima referencia	XX° GRAN PREMIO ARGENTINO HISTORICO 2023			PAG. N° 23

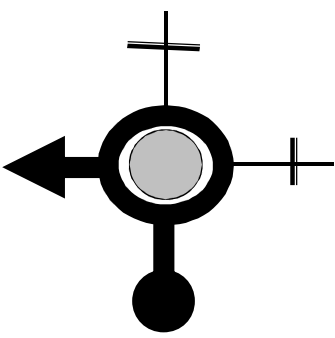
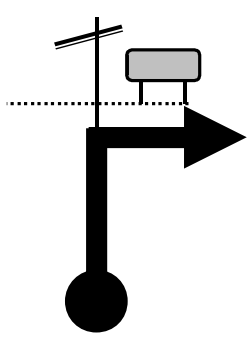

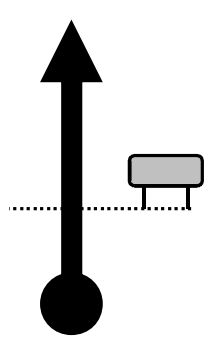
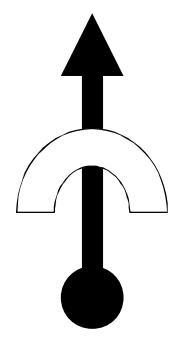
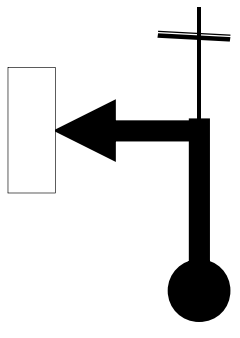
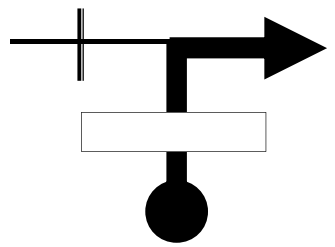

Sector Clasificadorio Nro: 1			CATAMARCA	ETAPA N°	
Km Totales del Sector : 202.270			HOSTERIA ALIJILAN	3	
Vel.	Dist. Total	Dist. Parcial	Direccion y Ubicacion de la Referencia	Referencia / Informacion	Hora de Carrera HH:MM:SS.CC
60	8.758	1.857		 COMIENZO ZONA DE CONTROL	03:39:45.47
60	11.0xx	2.2xx	CAMBIE LA VELOCIDAD A 63 KM/H. CUANDO SU RELOJ INDIQUE →		03:42:00.00
63	13.7xx	2.7xx			03:44:xx.xx
65				 PANCARTA BLANCA CON LEYENDA "A S" AUTOCONTROL SECRETO: 106	
65	15.9xx	2.2xx		 AUTOCONTROL: 107	03:46:__. __
70	velocidad proxima referencia	XX° GRAN PREMIO ARGENTINO HISTORICO 2023			PAG. N° 24

Sector Clasificadorio Nro: 1			CATAMARCA	ETAPA N°	
Km Totales del Sector : 202.270			HOSTERIA ALJILAN	3	
Vel.	Dist. Total	Dist. Parcial	Direccion y Ubicacion de la Referencia	Referencia / Informacion	Hora de Carrera HH:MM:SS.CC
70	17.3xx	1.3xx		 AUTOCONTROL: 108 FIN ZONA DE CONTROL	03:47:__.__
30	17.600	0.3xx		 CONTROL POLICIAL	03:48:xx.xx
30	17.700	0.100			03:48:xx.xx
80	20.750	3.050		RIO HUACRA	03:50:xx.xx
40	21.150	0.400		 TOMAR A LA DERECHA POR RUTA 64 A SGO. DEL ESTERO	03:51:xx.xx
40	velocidad proxima referencia	XX° GRAN PREMIO ARGENTINO HISTORICO 2023			PAG. N° 25

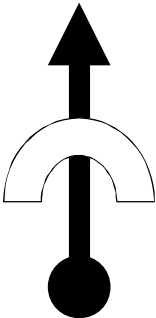
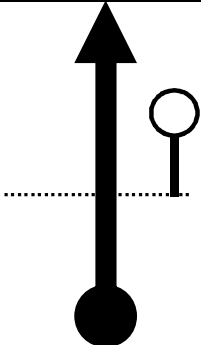
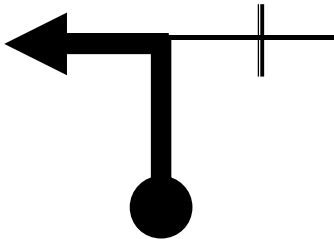
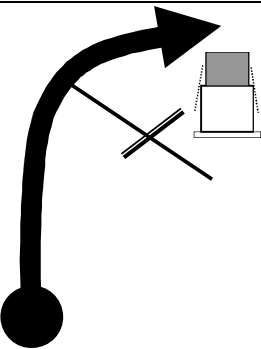
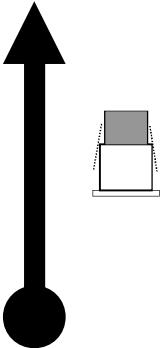

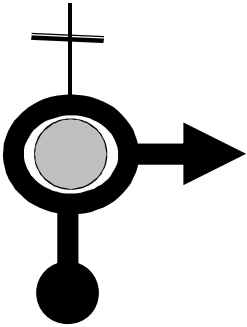
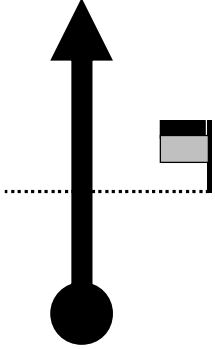
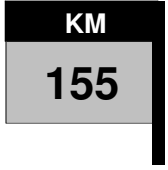
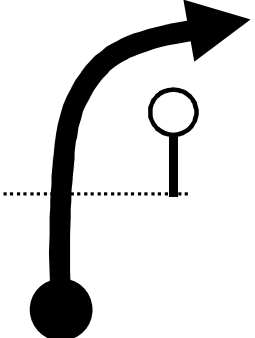

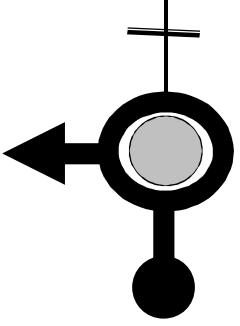
Sector Clasificadorio Nro: 1			CATAMARCA	ETAPA N°	
Km Totales del Sector : 202.270			HOSTERIA ALIJILAN	3	
Vel.	Dist. Total	Dist. Parcial	Direccion y Ubicacion de la Referencia	Referencia / Informacion	Hora de Carrera HH:MM:SS.CC
40	21.500	0.350			03:52:xx.xx
85	29.600	8.100		 ZONA URBANA	03:57:xx.xx
40	30.800	1.200		TOMAR RUTA 64 A EL ABRA	03:59:xx.xx
40	31.820	1.020		 	04:01:xx.xx
40	32.200	0.380		<u>CONTROL DE SELLO N° 8</u> SOBRE LA BANQUINA PROHIBIDO DETENERSE SOBRE LA RUTA	04:02:00.00
85	velocidad proxima referencia	XX° GRAN PREMIO ARGENTINO HISTORICO 2023			PAG. N° 26

Sector Clasificadorio Nro: 1			CATAMARCA	ETAPA N°	
Km Totales del Sector : 202.270			HOSTERIA ALIJILAN	3	
Vel.	Dist. Total	Dist. Parcial	Direccion y Ubicacion de la Referencia	Referencia / Informacion	Hora de Carrera HH:MM:SS.CC
85	41.570	9.370		RIO MANANTIALES	04:08:xx.xx
85	44.800	3.230		PORTICO DE ENTRADA A ALIJILAN	04:10:xx.xx
40	45.800	1.000		INGRESO A HOSTERIA ALIJILAN	04:12:xx.xx
40	<p>COMIENZA NEUTRALIZACION DE 45 MINUTOS EN LA HOSTERIA DONDE SE SERVIRA UN REFRIGERIO. LUEGO, EN PUEBLO LOS ALTOS, A 14 Km (PAGINA 28 CUADROS 4 Y 5) HAY 2 ESTACIONES DE SERVICIO DE BANDERA BLANCA POR SI NECESITA COMBUSTIBLE. TIENE 15 MINUTOS EXTRA.</p> <p>RESPETE LOS HORARIOS, NO SE ADELANTE !!!!!!!!!</p>				
40	46.000 0.000	0.200 0.000		SALIR DE HOSTERIA HACIA LOS ALTOS	04:57:xx.xx
40	velocidad proxima referencia	XX° GRAN PREMIO ARGENTINO HISTORICO 2023			PAG. N° 27

Sector Clasificadorio Nro: 2			HOSTERIA ALIJILAN	ETAPA N°	
Km Totales del Sector : 101.350			CATAMARCA	3	
Vel.	Dist. Total	Dist. Parcial	Direccion y Ubicacion de la Referencia	Referencia / Informacion	Hora de Carrera HH:MM:SS.CC
40	1.000	1.000		PORTICO DE SALIDA DE ALIJILAN	04:59:xx.xx
85	13.380	12.380		ZONA URBANA LOS ALTOS	05:07:xx.xx
40	13.970	0.590		TOMAR A LA IZQUIERDA POR RUTA 64 A TUCUMAN	05:08:xx.xx
40	14.100	0.130		SEGUIR POR RUTA 64 ESTACION DE SERVICIO NEUTRALIZA 15 MINUTOS	05:09:xx.xx
40	14.600	0.500		ESTACION DE SERVICIO	05:24:xx.xx
40	velocidad proxima referencia	XX° GRAN PREMIO ARGENTINO HISTORICO 2023			PAG. N° 28

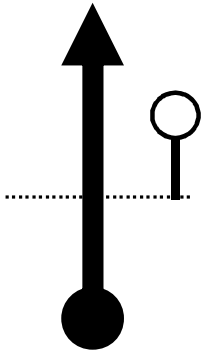

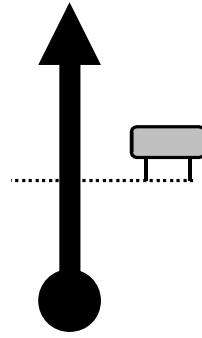
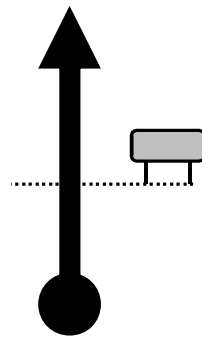
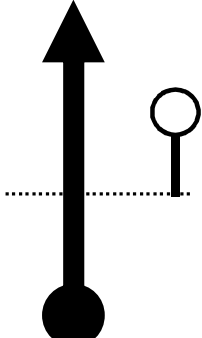
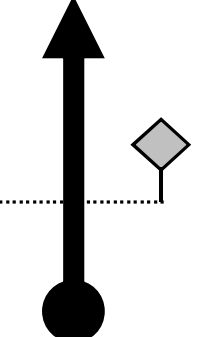

Sector Clasificadorio Nro: 2			HOSTERIA ALIJILAN		ETAPA N°
Km Totales del Sector : 101.350			CATAMARCA		3
Vel.	Dist. Total	Dist. Parcial	Direccion y Ubicacion de la Referencia	Referencia / Informacion	Hora de Carrera HH:MM:SS.CC
40	14.900	0.300		TOMAR A LA DERECHA POR RUTA 64 A TUCUMAN	05:25:xx.xx
40	15.370	0.470			05:25:xx.xx
85	<p>SI ESTA ADELANTADO ESPERE EN ESTA ZONA DE LA RUTA 64 LUEGO DE LA ROTONDA DEL CUADRO 5 Y HASTA LA AUTOLARGADA DEL PC N° 37 NO HAY LUGAR PARA ESPERAR.</p>				
85	24.210	8.840		 CURVA CERRADA	05:32:xx.xx
40	24.600	0.390		 TOMAR A LA IZQUIERDA POR RUTA 38 A CATAMARCA	05:32:xx.xx
40	velocidad proxima referencia	XX° GRAN PREMIO ARGENTINO HISTORICO 2023			PAG. N° 29

Sector Clasificadorio Nro: 2			HOSTERIA ALIJILAN		ETAPA N°
Km Totales del Sector : 101.350			CATAMARCA		3
Vel.	Dist. Total	Dist. Parcial	Direccion y Ubicacion de la Referencia	Referencia / Informacion	Hora de Carrera HH:MM:SS.CC
40	24.980	0.380			05:33:xx.xx
70	27.960	2.980			05:35:xx.xx
40	28.300	0.340		CONTROL POLICIAL	05:36:xx.xx
40	29.080 0.000	0.780 0.000		PANCARTA ROJA EN ULTIMA LINEA BLANCA SOBRE RUTA COMIENZA P.C. N° 37	05:40:00.00
68	0.988	0.988		1° REVES DE CARTEL RECTANGULAR	05:40:52.32
68	velocidad proxima referencia	XX° GRAN PREMIO ARGENTINO HISTORICO 2023			PAG. N° 30

Sector Clasificadorio Nro: 2			HOSTERIA ALIJILAN	ETAPA N°	
Km Totales del Sector : 101.350			CATAMARCA	3	
Vel.	Dist. Total	Dist. Parcial	Direccion y Ubicacion de la Referencia	Referencia / Informacion	Hora de Carrera HH:MM:SS.CC
68	2.331	1.343			05:42:03.41
68	3.269	0.938		PELIGRO ZONA DE DERRUMBES	05:42:53.07
68	5.334	2.065		PELIGRO ZONA DE DERRUMBES	05:44:42.39
68	7.222	1.888		COMIENZO ZONA DE CONTROL	05:46:22.34
68	7.8xx	0.6xx			05:46:xx.xx
63	velocidad proxima referencia	XX° GRAN PREMIO ARGENTINO HISTORICO 2023			PAG. N° 31

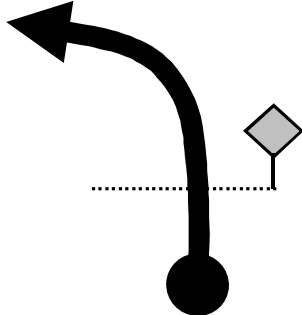

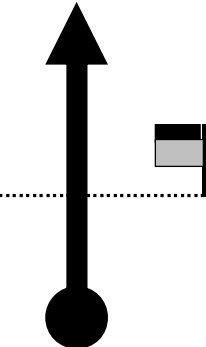
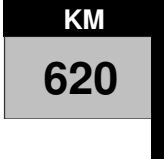
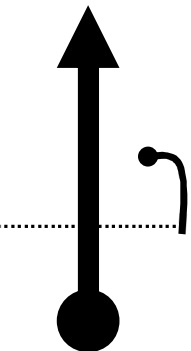
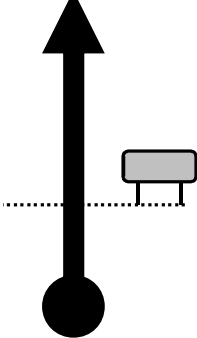
Sector Clasificadorio Nro: 2			HOSTERIA ALIJILAN		ETAPA N°
Km Totales del Sector : 101.350			CATAMARCA		3
Vel.	Dist. Total	Dist. Parcial	Direccion y Ubicacion de la Referencia	Referencia / Informacion	Hora de Carrera HH:MM:SS.CC
63	11.6xx	3.7xx		 AUTOCONTROL: 109	05:50:__.__
63	13.6xx	2.0xx		 AUTOCONTROL: 110	05:52:__.__
68				 PANCARTA BLANCA CON LEYENDA "A S" AUTOCONTROL SECRETO: 111	
68	17.2xx	3.5xx		 FIN ZONA DE CONTROL	05:55:xx.xx
60	17.600	0.3xx		 SEGUIR A LA IZQUIERDA POR RUTA 38 A CATAMARCA	05:55:xx.xx
60	velocidad proxima referencia	XX° GRAN PREMIO ARGENTINO HISTORICO 2023			PAG. N° 32

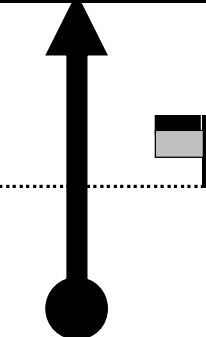
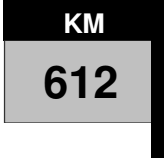

Sector Clasificadorio Nro: 2			HOSTERIA ALIJILAN		ETAPA N°
Km Totales del Sector : 101.350			CATAMARCA		3
Vel.	Dist. Total	Dist. Parcial	Direccion y Ubicacion de la Referencia	Referencia / Informacion	Hora de Carrera HH:MM:SS.CC
60	18.200	0.600		CRUCE RUTA 9 SEGUIR POR RUTA 38	05:56:xx.xx
60	20.470 0.000	2.270 0.000		 COMIENZA P.C. N° 38	06:03:00.00
82	1.246	1.246		 KM 626	06:03:54.71
82	2.572	1.326			06:04:52.92
82	4.863	2.291			06:06:33.50
80	velocidad proxima referencia	XX° GRAN PREMIO ARGENTINO HISTORICO 2023			PAG. N° 33

Sector Clasificadorio Nro: 2			HOSTERIA ALIJILAN	ETAPA N°	
Km Totales del Sector : 101.350			CATAMARCA	3	
Vel.	Dist. Total	Dist. Parcial	Direccion y Ubicacion de la Referencia	Referencia / Informacion	Hora de Carrera HH:MM:SS.CC
80	6.150	1.287			06:07:31.40
80	7.277	1.127			06:08:22.10
80	10.057	2.780		ULTIMA COLUMNA DE LUZ COMIENZO ZONA DE CONTROL	06:10:27.21
80	12.2xx	2.2xx			06:12:xx.xx
82	15.3xx	3.0xx			06:14:xx.xx
80	velocidad proxima referencia	XX° GRAN PREMIO ARGENTINO HISTORICO 2023			PAG. N° 34

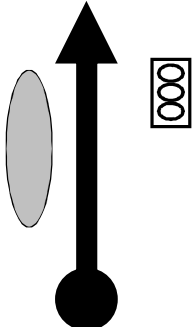
Sector Clasificadorio Nro: 2			HOSTERIA ALIJILAN	ETAPA N°	
Km Totales del Sector : 101.350			CATAMARCA	3	
Vel.	Dist. Total	Dist. Parcial	Direccion y Ubicacion de la Referencia	Referencia / Informacion	Hora de Carrera HH:MM:SS.CC
80	16.9xx	1.6xx		 ACCESO A PALO LABRADO	06:15:xx.xx
80	18.2xx	1.2xx		VALOR DEL ESPACIO 00:00:57.41 	06:16:xx.xx
82	22.2xx	4.0xx		 AUTOCONTROL: 112	06:19:__. __
82	26.4xx	4.1xx		 DESPUES DE KM 601 AUTOCONTROL: 113	06:22:__. __
80				 PANCARTA BLANCA CON LEYENDA "A S" AUTOCONTROL SECRETO: 114	
80	velocidad proxima referencia	XX° GRAN PREMIO ARGENTINO HISTORICO 2023			PAG. N° 35

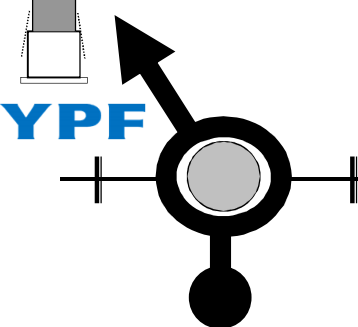
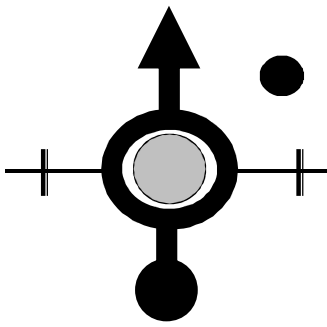
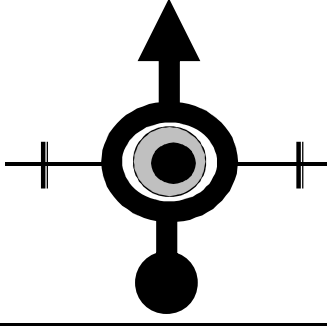
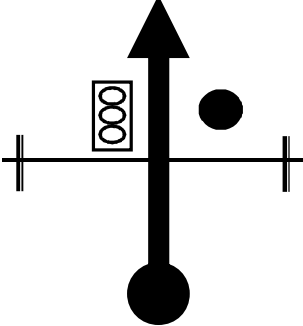
Sector Clasificadorio Nro: 2			HOSTERIA ALIJILAN	ETAPA N°	
Km Totales del Sector : 101.350			CATAMARCA	3	
Vel.	Dist. Total	Dist. Parcial	Direccion y Ubicacion de la Referencia	Referencia / Informacion	Hora de Carrera HH:MM:SS.CC
80	29.3xx	2.9xx		 FIN ZONA DE CONTROL	06:24:xx.xx
80	34.020	4.6xx		CRUCE DE CUESTA DEL PORTEZUELO	06:28:xx.xx
80	40.000	5.980		 CONTROL POLICIAL	06:32:xx.xx
60	41.600	1.600	 AXION	 SEGUIR AL FRENTE A CATAMARCA CENTRO	06:34:xx.xx
60	42.460	0.860		SEGUIR AL FRENTE A TRES PUENTES POR AV. CNEL FELIPE VARELA	06:35:xx.xx
60	velocidad proxima referencia	XX° GRAN PREMIO ARGENTINO HISTORICO 2023			PAG. N° 36

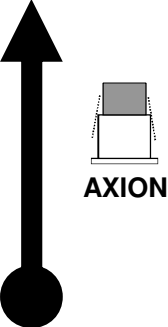
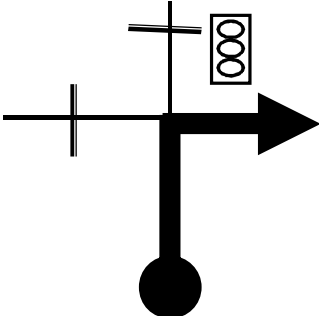
Sector Clasificadorio Nro: 2			HOSTERIA ALIJILAN	ETAPA N°	
Km Totales del Sector : 101.350			CATAMARCA	3	
Vel.	Dist. Total	Dist. Parcial	Direccion y Ubicacion de la Referencia	Referencia / Informacion	Hora de Carrera HH:MM:SS.CC
60	44.700	2.240		 COMIENZA BOULEVARD	06:37:xx.xx
60	45.100	0.400		ROTONDA DEL ABORIGEN SEGUIR AL FRENTE POR AV. PTE. CASTILLO	06:37:xx.xx
60	45.650	0.550		● EL AMIGO ROTONDA DE VALLE VIEJO SEGUIR AL FRENTE	06:38:xx.xx
60	47.320	1.670		● CORONA SEGUIR AL FRENTE	06:40:xx.xx
40	48.750	1.430		● VERDULERIA	06:42:xx.xx
40	velocidad proxima referencia	XX° GRAN PREMIO ARGENTINO HISTORICO 2023			PAG. N° 37

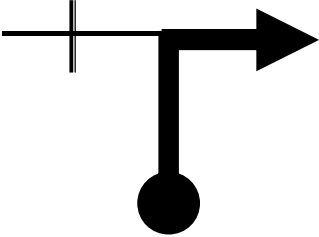
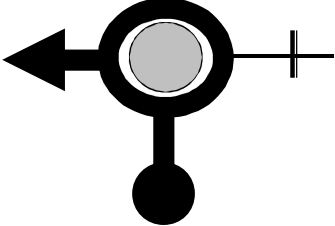
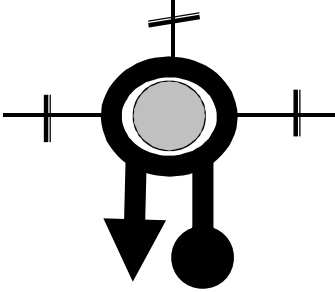
Sector Clasificadorio Nro: 2			HOSTERIA ALIJILAN	ETAPA N°	
Km Totales del Sector : 101.350			CATAMARCA	3	
Vel.	Dist. Total	Dist. Parcial	Direccion y Ubicacion de la Referencia	Referencia / Informacion	Hora de Carrera HH:MM:SS.CC
40	49.000	0.250			06:42:xx.xx
40	49.250	0.250		 EN 1° SEMAFORO LUEGO DE LA AXION TOMAR A LA DERECHA POR AV. LOS MISIONEROS	06:42:xx.xx
40	50.300	1.050		TOMAR CALLE SONZINI	06:44:xx.xx
40	50.500	0.200		TOMAR AV. AUTONOMIA DE CATAMARCA	06:44:xx.xx
40	51.450	0.950		LUEGO DEL ESTADIO UTILIZAR ROTONDA PARA RETOMAR	06:46:xx.xx
40	velocidad proxima referencia	XX° GRAN PREMIO ARGENTINO HISTORICO 2023			PAG. N° 38

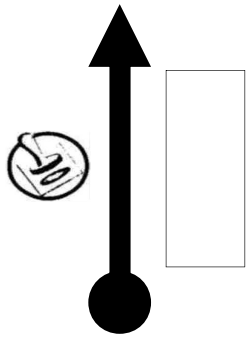
Sector Clasificadorio Nro: 2			HOSTERIA ALIJILAN	ETAPA N°	
Km Totales del Sector : 101.350			CATAMARCA	3	
Vel.	Dist. Total	Dist. Parcial	Direccion y Ubicacion de la Referencia	Referencia / Informacion	Hora de Carrera HH:MM:SS.CC
40	51.800	0.350		<p><u>CONTROL DE SELLO N° 9</u></p> <p><u>FRENTE AL PREDIO FERIAL</u></p>	06:47:00.00

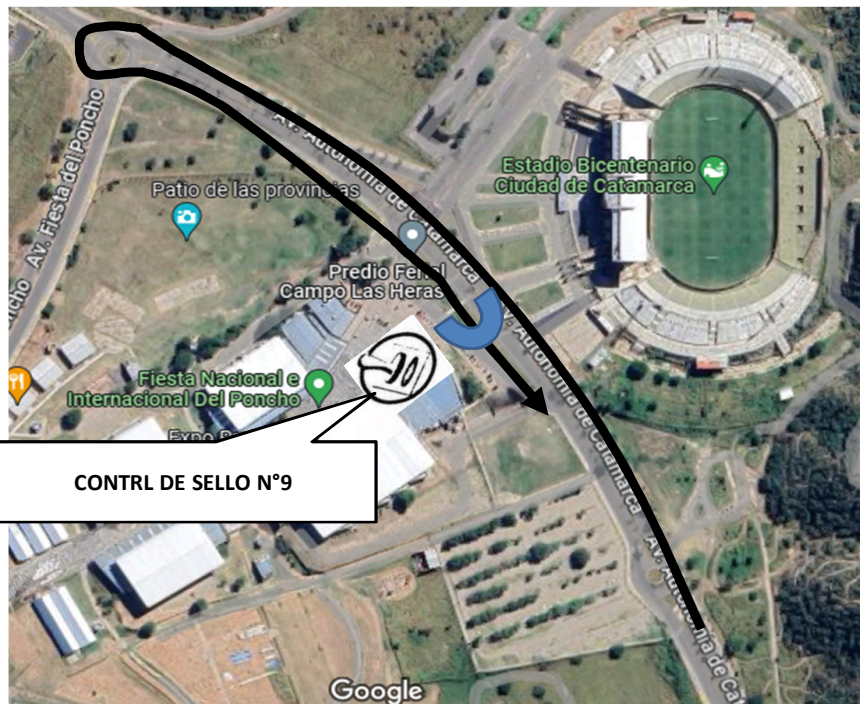

PLANILLA AUTOCONTROLES		AUTO N°	
PILOTO		COPILOTO	
ENTREGAR JUNTO CON EL RELOJ S.A.D. EN EL CONTROL DE SELLO FINAL			
AUTOC. N° 88		AUTOC. N° 109	
AUTOC. N° 89		AUTOC. N° 110	
AUTOC. N° 90		AUTOC. N° 111	
AUTOC. N° 91		AUTOC. N° 112	
AUTOC. N° 92		AUTOC. N° 113	
AUTOC. N° 93		AUTOC. N° 114	
AUTOC. N° 94			
AUTOC. N° 95			
AUTOC. N° 96			
AUTOC. N° 97			
AUTOC. N° 98			
AUTOC. N° 99			
AUTOC. N° 100			
AUTOC. N° 101			
AUTOC. N° 102			
AUTOC. N° 103			
AUTOC. N° 104			
AUTOC. N° 105			
AUTOC. N° 106			
AUTOC. N° 107			
AUTOC. N° 108			
FIRMA:			